



Creative Conners, Inc

# **PUSHSTICK MINI**™

REFERENCE MANUAL V1.0

# GETTING STARTED

Congratulations on your purchase of the **Pushstick Mini** deck winch from Creative Conners, Inc. The **Pushstick Mini** is a compact winch designed from the ground up to meet the rigorous demands expected from professional stage machinery. The **Pushstick Mini** is a smart machine; the Stagehand controller is built in. Simply connect the 120v input power, Ethernet and Showstopper cables and you'll be ready to *Make It Move!*

This manual will direct you through:

1. Unpacking
2. Installing & Testing
3. Operation Procedures

If you need help along the way, contact us!

- Online: [www.creativeconners.com](http://www.creativeconners.com)
- Email: [support@creativeconners.com](mailto:support@creativeconners.com)
- Phone: 401-289-2942 x2

## A Word About Safety

The **Pushstick Mini** is a fantastic machine for moving scenery. Do not let the “Mini” mislead you - it can pull large, heavy scenery across the stage with ease. Such power deserves a great degree of respect, as it can become a very serious hazard if misused. Proper deck rigging practices should always be employed when installing a **Pushstick Mini**.

- The **Pushstick Mini** is constructed to be a rugged and versatile winch, used for deck tracks, traveler tracks, and other lateral motion applications.
  - **Pushstick Mini** winches are not intended for hoisting
- Each **Pushstick Mini** has a label indicating its maximum line pull. This is the maximum linear force that can be continuously generated by the winch's motor and gearbox.
- The **Pushstick Mini** ships with a set of Lexan safety shields to prevent injury to personnel or damage to the winch. Although they are removable, these covers are intended to be installed whenever the winch is in service.

## What's included

1. **Pushstick Mini** winch
2. 10' power cable

## Required Tools

1. 3/4" socket wrench (cable tensioning)
2. 9/16" wrench (pinch rollers)

3. 7/16" wrench (fairlead adjustment)
4. 3/16" hex key (fairlead adjustment)
5. 5/32" hex key (drum cable termination)
6. 9/64" hex key (limit switches)
7. Philips head screwdriver (safety shields)

## Features

- 85ft cable capacity - mini winch, maximum distance!
- 36in/s max speed - the **Pushstick Mini** can keep up with it's big brother, the **Pushstick v2**!
- 90lb line pull - enough for almost any traveler track, and it can still hold its own with pallets and smaller wagons!
- Zero-fleet design - no fleet angle headaches!
- External cable clips - rig and strip the winch drum in a flash!
- Belt-driven power train - no more greasy chain!
- Independant fairleads - rig only the amount of travel you need!
- Onboard control - minimize footprint; the **Stagehand** is built right in!
- 120VAC 10A input power - run it in a classroom, or rehearsal space!

# Overview

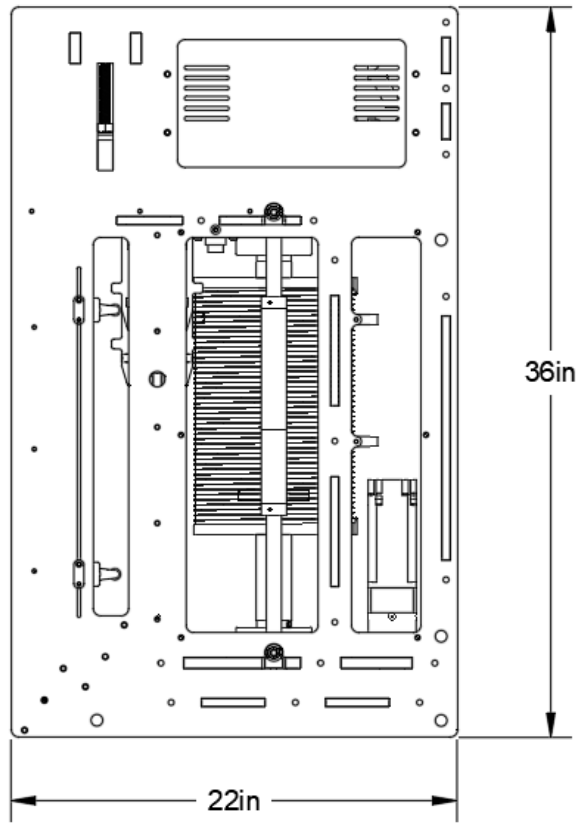
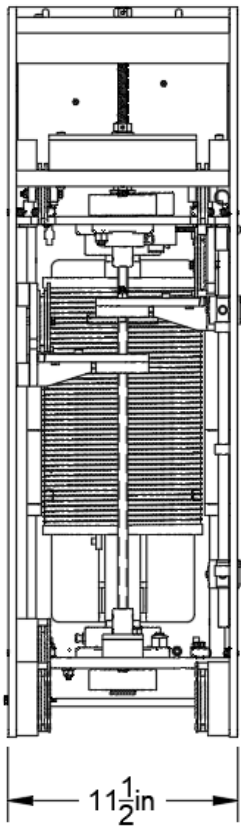
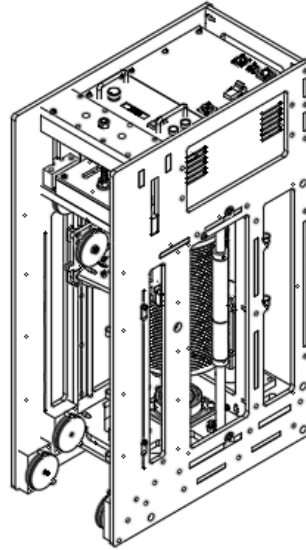
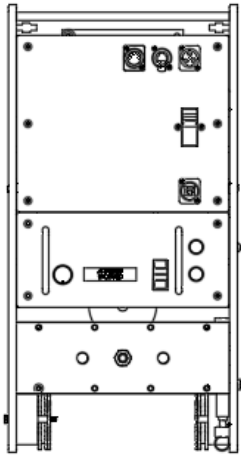

*Overview dimensions*

# Stagehand Controller

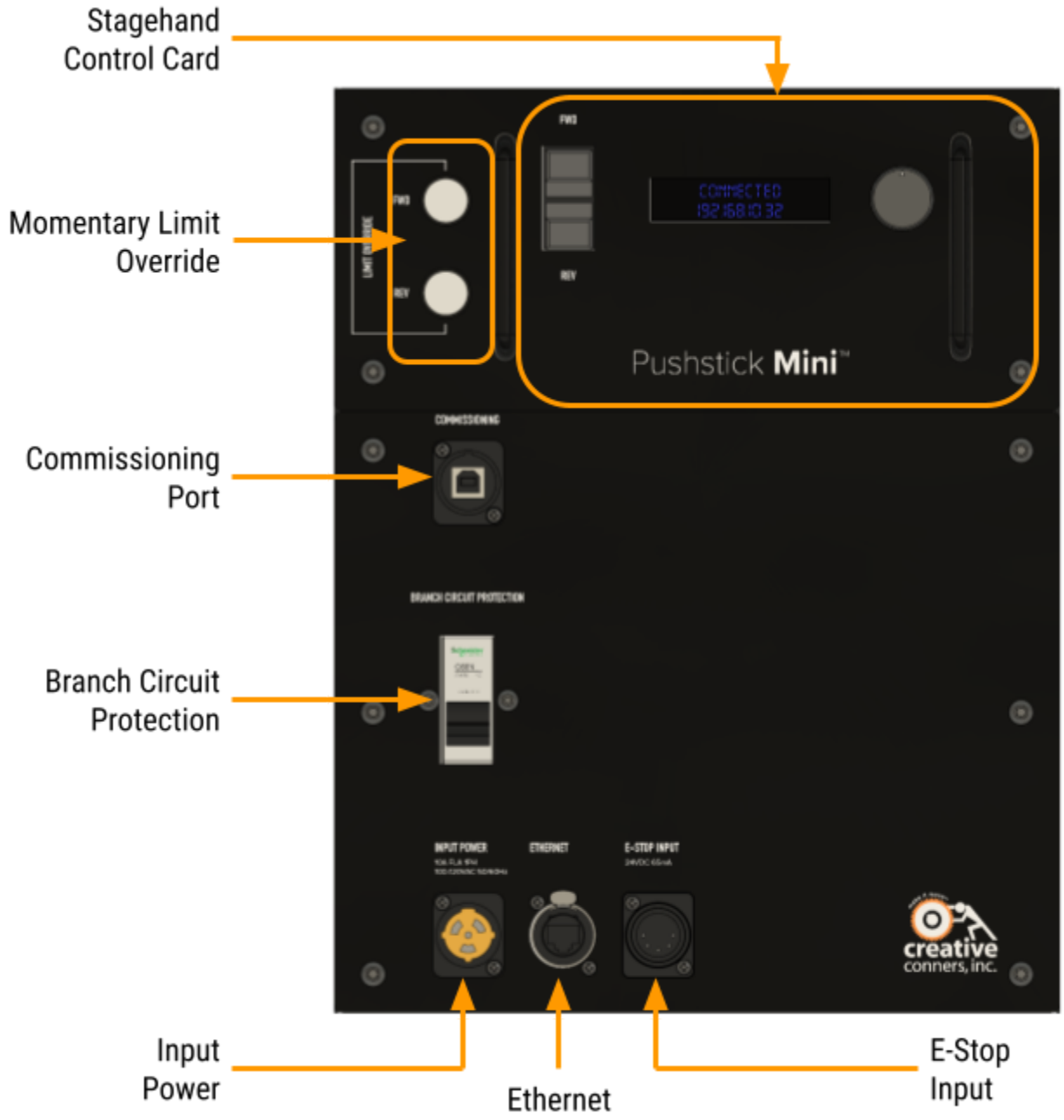

# INSTALLATION

The **Pushstick Mini** is designed to be mounted in any orientation. When determining a mounting position, please keep a few things in mind:

- The rated continuous line pull of the **Pushstick Mini** is 90lb, but it can reach up to 270lb before the machine faults.
- The **Pushstick Mini** weighs 170lb (185lbs with the hanging bracket)

Remember to design any mounting positions with sufficient safety factors.

Cables can exit the **Pushstick Mini** out the front or top of the frame. When cables exit the front of the machine, they are already at the proper height to mule through Creative Conners, Inc deck hardware. When rigged to exit out the top of the frame, custom hardware may be required. Please contact Creative Conners, Inc with further questions.

The **Pushstick Mini** is not intended for outdoor use. Not only does the motor not like getting wet, the Stagehand controls will likely fail if exposed to water.

## Installation Options

### Ground Installation

The **Pushstick Mini** frame has 0.5" mounting holes, designed to work with standard Unistrut 90° brackets. These brackets allow you to attach the winch standing up or laying on its back.

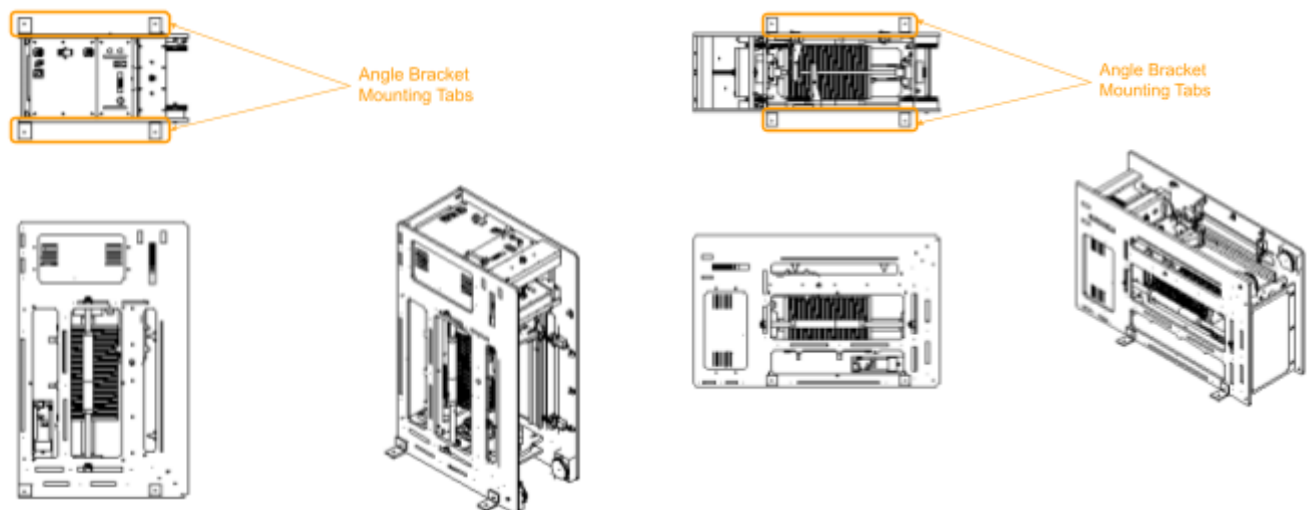

Vertical Installation

Horizontal Installation

## Track Installation

Additionally, when used as a traveler track machine, a hanging bracket accessory is available to allow the **Pushstick Mini** to mount to truss, track, or a batten.

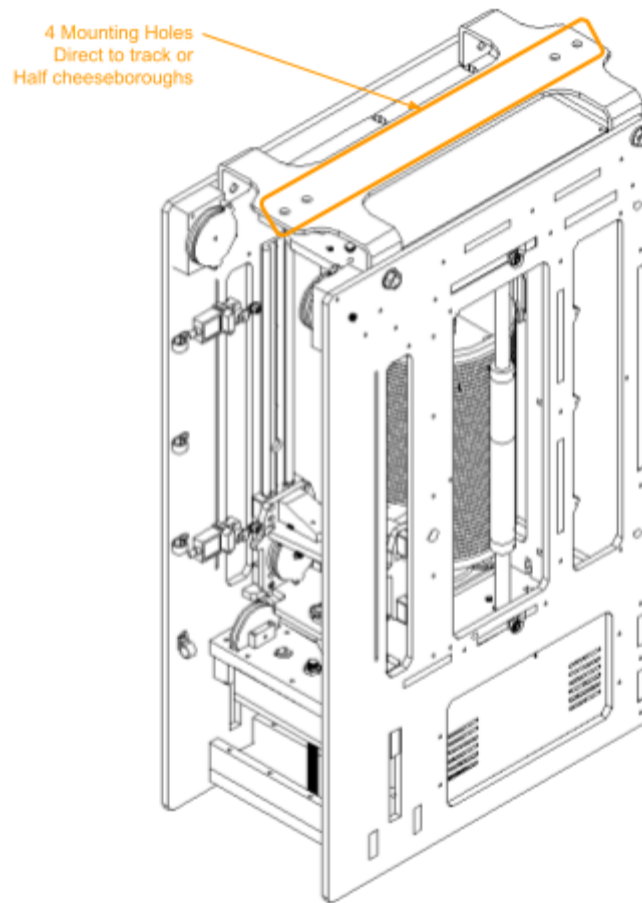

*Hanging Installation*

## MAKING THE CONNECTIONS

The **Pushstick Mini** is part of Creative Conners, Inc's line of smart machines. The **Stagehand** motion controller is built right in! Below is a list of all the connections required to integrate a **Pushstick Mini** in your **Spikemark** network.

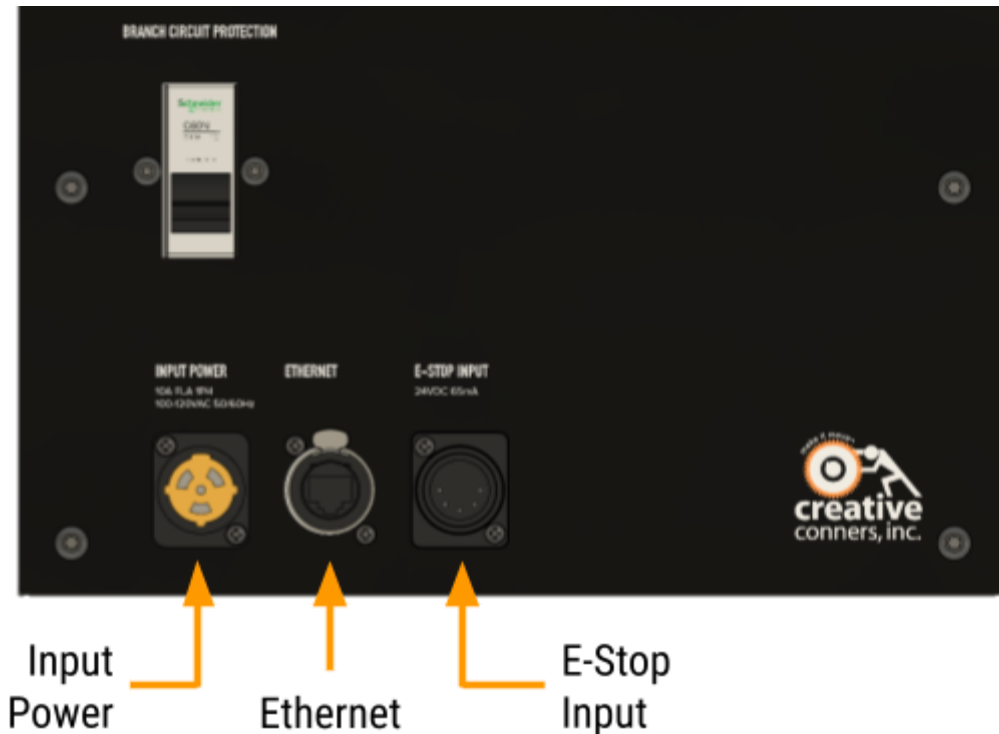

*Input Connections*

## Input Power

The **Pushstick Mini** requires 120VAC, 10A input power. As an added feature there is local branch circuit protection built into the machine. The circuit breaker is a great way to know for certain that the machine will not move when servicing, and is also a convenient method to reboot the internal electronics if required.

The power inlet of the **Pushstick Mini** is a Neutrik powerCON TRUE1 Appliance Inlet (NAC3MPX). The mating connection on the included power cord is a NAC3FX-W connector. The powerCON TRUE1 is rated for breaking capacity meaning it is safe to disconnect under load. The TRUE1 connectors are not compatible with standard “Blue” powerCON connectors. See below for wiring details inside the connector.

TERMINAL	WIRE COLOR
L - Line	Black
N - Neutral	White
G - Ground	Green

Detailed wiring instructions can be found in the Specifications section.



## E-Stop

The **Showstopper** is Creative Conners, Inc's emergency stop safety controller. Each **Stagehand** and smart machine requires a direct connection to a **Showstopper 3 Base** or **Showstopper 3 Hub**. These connections are made with a Neutrik 5-pin XLR cable. There's no tech wizardry here, any 5-pin XLR cable will work as long as the polarity is correct. See below for connection details.

PIN	CONNECTION
1	COM
2	N.C.
3	N.C.
4	N.C.
5	+24VDC

## Ethernet

Although the **Pushstick Mini** can be manually jogged from the onboard **Stagehand** controller, the real power is realized when connected through the network to **Spikemark** software. As with all **Stagehands** or Smart Machines, each controller must be connected to the network with an Ethernet (CAT5/CAT6) cable back to a network switch. The **Pushstick Mini** has a Neutrik etherCON receptacle which accepts the rugged etherCON connector or a standard RJ45.

## IP Address

Once the **Pushstick Mini** is physically connected to the network you will need to set the IP address in order to communicate with **Spikemark**. This is accomplished the same way as any other **Stagehand** controller.

- Click the jog wheel, the SET IP screen will be displayed
- Scroll to the octet you want to change and click the wheel
- Turn the wheel to increase or decrease the number until you reach your desired value. Click the jog wheel to set the value.
- Repeat the process for all octets that need to be adjusted.
- Once complete use the jog wheel to highlight 'OK' and click the wheel

## Subnet Mask

In addition to the IP address each **Stagehand** controller also has the ability to set the subnet mask. The default subnet mask is 255.255.255.0. If you find yourself in a position where you need to

adjust the subnet mask, please take a step back and ask yourself if it is really necessary. If the answer is yes, click and hold the scroll wheel to reveal the SET SUBNET screen. Follow the same procedures used to set the IP address to adjust the subnet mask.

## RIGGING THE MACHINE

If you are unfamiliar with rigging a zero-fleet winch, be prepared; it is a bit different than a standard winch. If you find yourself in the weeds at any point while rigging the machine, give us a call at 401-289-2942 x2, or drop us a line at [support@creativeconnors.com](mailto:support@creativeconnors.com)

Before you begin, here are a few important tips:

- When a side of the machine is mentioned, we are referencing what you see when the machine is standing vertical and looking at the open front of the machine.
- Loading cable is best done as a team. One person will need to have their hands inside the moving machine. It is the responsibility of all team members to be on the lookout for dangerous situations, and to stop the process if there is ever a risk of injury or damage.
- Disconnect the winch from the **Spikemark** network before loading cable, this ensures only a team member touching the winch can control its movement. Remote movement is an unnecessary risk during cable loading.
- Drive the winch slowly whenever hands/tools are inside the body of the winch. Always be ready to stop motion. It may be helpful to have a team member standing by to use a **Showstopper Remote** to initiate an emergency stop.

# CABLE PATH

Before moving on to the actual rigging, let's take a look at how the drive cable is routed internally. Understanding the cable path is a fundamental building block to successfully rigging the **Pushstick Mini**.

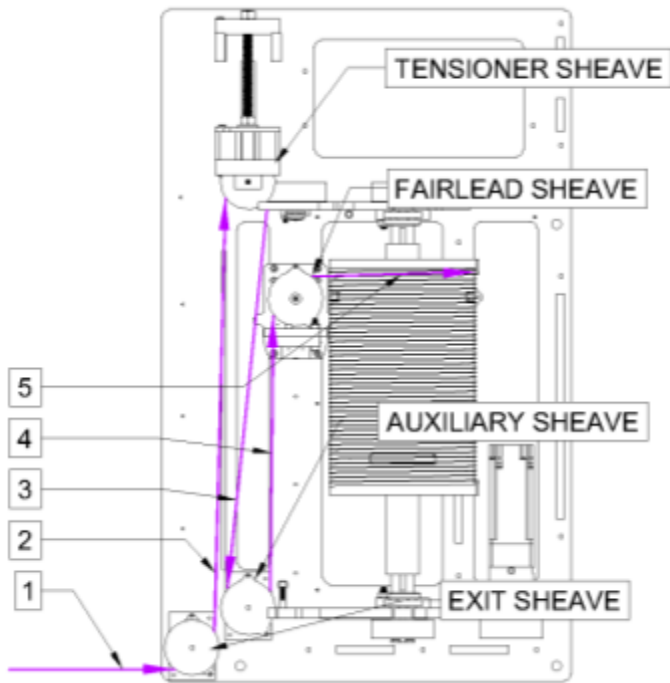

*Left Side*

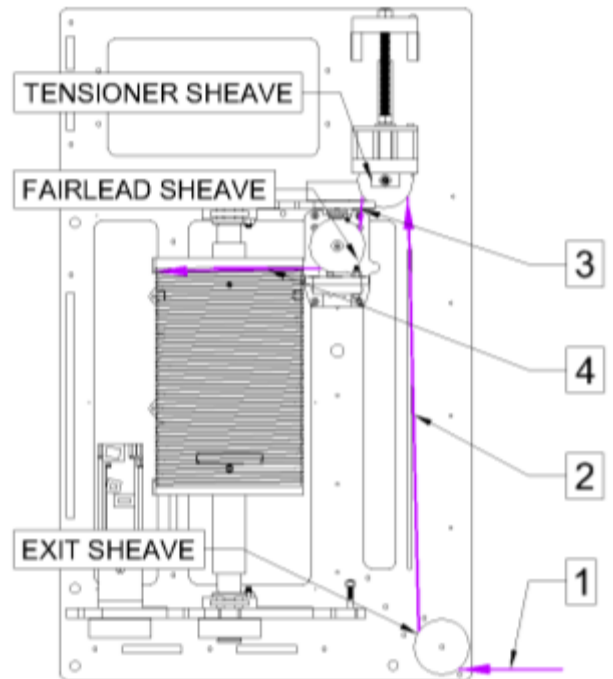

*Right Side*

1. Cable Entry
2. To Tensioner
3. To Aux Sheave
4. To Fairlead
5. To Drum

1. Cable Entry
2. To Tensioner
3. To Fairlead
4. To Drum

# Full Rigging

If you intend to use all 85' of travel on the **Pushstick Mini** drum, follow the steps below:

1. Grab a spool of 3/16" aircraft cable, placing it on the right side of the **Pushstick Mini**.
2. Run cable through your rig, returning to the left side of the **Pushstick Mini**.
3. Lower the tensioner until the plastic guide blocks are in the bottom of their channels.
4. Move each limit switch to its extreme position (up or down).
5. Drive the winch until the lower fairlead is about to touch the bottom of the lead screw.
6. Take the cut end of the aircraft cable and thread it through the left-side exit sheave, taking care to pass the cable through the standoffs.
7. From the exit sheave, run the cable up through the left-side tensioner sheave.
8. From the tensioner sheave, run the cable down, past the fairlead, to the auxiliary sheave.
9. From the auxiliary sheave, run the cable back up to the fairlead, and pass it over the top of the left-side fairlead sheave, and into the lowest groove on the drum.
10. Loosen or remove the external cable clip on the bottom of the drum, and pass the cable through the hole in the drum body.
  - a. Leave no more than a 6" tail inside the drum
11. Lay the cable in the lowest groove on the drum, and reattach the external cable clip.
12. Begin driving the winch, keeping an eye on the cable wraps. Ensure that they are laying neatly in their grooves.
13. With 3 grooves left on the drum, reduce speed to a crawl and complete the drum wrapping.
14. The bottom of the fairlead sheave should be aligned with the top groove and the cable keeper should be on the side of the drum.
15. Cut the cable, leaving 5' outside the machine.
16. Take the end of the 5' tail and pass it through the right-hand exit sheave.
17. From the exit sheave, pass the cable up to the right-hand tensioner sheave.
18. From the tensioner sheave, pass the cable beneath the right-hand fairlead sheave and into the drum.
19. Loosen or remove the external cable clip on the top of the drum, and pass the cable through the hole in the drum body.
20. Lay the cable in the highest groove on the drum, and reattach the external cable clip.
21. Use your 3/4" wrench to raise the tensioner until the slack is removed from the system.
22. Drive the winch forward and backward a few times with no load to confirm proper operation.

## Partial Rigging

If you need fewer feet of travel, the **Pushstick Mini** has got you covered. You only need to load as much cable as you'll use.

1. Grab a spool of 3/16" aircraft cable, placing it on the right side of the **Pushstick Mini**.
2. Run the cable through your rig, returning to the **Pushstick Mini**.
3. Calculate the number of wraps of cable you'll need. Each complete wrap around the drum is about 24" of travel.
4. Lower the tensioner until the plastic guide blocks are in the bottom of their channels.
5. Move each limit switch to its extreme position (up or down).
6. Drive the winch until the lower fairlead is about to touch the bottom of the lead screw.
7. Take the cut end of the aircraft cable and thread it through the left-side exit sheave, taking care to pass the cable through the standoffs.
8. From the exit sheave, run the cable up through the left-side tensioner sheave.
9. From the tensioner sheave, run the cable down, past the fairlead, to the auxiliary sheave.
10. From the auxiliary sheave, run the cable back up to the fairlead, and pass it over the top of the left-side fairlead sheave, and into the lowest groove on the drum.
11. Loosen or remove the external cable clip on the bottom of the drum, and pass the cable through the hole in the drum body.
12. Lay the cable in the lowest groove on the drum, and reattach the external cable clip.
13. Begin driving the winch, keeping an eye on the cable wraps. Ensure that they are laying neatly in their grooves.
14. The first (3) wraps on the drum are safety wraps, begin counting wraps after the (3) safety wraps are completed.
15. After the correct number of wraps are laid, cut the aircraft cable, leaving 5' outside the winch frame.
16. Using your 3/16" hex key and 7/16" wrench, remove the socket-head cap screw that attaches the lead screw nut to the fairlead arm.
17. Spin the lead screw nut until the bottom of the fairlead sheave is even with the third groove from the top of the drum. For reference, every complete rotation of the lead screw nut will cause the fairlead arm to raise the height of one groove on the drum.
18. Take the end of the 5' tail and pass it through the right-hand exit sheave.
19. From the exit sheave, pass the cable up to the right-hand tensioner sheave.
20. From the tensioner sheave, pass the cable beneath the right-hand fairlead sheave and into the drum.
21. Drive the winch at a crawl to lay the final (3) wraps of cable.
22. Loosen or remove the external cable clip on the top of the drum, and pass the cable through the hole in the drum body.
23. Lay the cable in the highest groove on the drum, and reattach the external cable clip.
24. Use your 3/4" wrench to raise the tensioner until the slack is removed from the system.
25. Drive the winch forward and backward a few times with no load to confirm proper operation.

## Setting the Limits

Setting the limits on the **Pushstick Mini** is a simple, straightforward process. Each fairlead has a striker which protrudes out and actuates the arm of a limit switch. After rigging the winch, and attaching the cable to your scenery, complete the following steps:

1. Slowly drive the winch until the scenery is in its maximum position in that direction.
2. Use your 9/64" hex key to loosen the (2) #8 socket-head cap screws that hold the limit in place.
3. Slide the limit up or down until it contacts the striker on the fairlead.
4. Tighten the limit switch in its new position.
5. Repeat steps 1-4 for travel in the opposite direction.

## TROUBLESHOOTING

We aim to make any product as plug and play as possible, though sometimes challenges crop up right out of the box or years down the road. See below for solutions to common operational challenges.

### Motion

Issue	Checkpoint
Motion is not smooth	Confirm cable is wrapped correctly on drum
	Confirm cable rigged correctly through any mule and turnaround pulleys
	Confirm deck track is clear of obstructions
	Check PID tuning in Spikemark: <ul style="list-style-type: none"><li>• Proportional Gain = 2</li><li>• Integral Gain = 1</li><li>• Integral Limit = 1000</li></ul>
Motor is spinning, drum is not moving	Confirm lower drive belt is connected and intact
Drum is spinning, fairlead is not moving	Confirm upper drive belt is connected and intact

## Stagehand Display

Stagehand Display	Checkpoint
E STOP + IP Address	The E-stop cable is unplugged or the E-stop is engaged
DISCONNECTED + IP Address	Machine is on and ready to connect to Spikemark
CONNECTED + IP Address	Machine is on and connected to Spikemark
SET IP	Confirm the IP Address is correct, use the scroll wheel to highlight OK and click
SET SUBNET	Confirm display shows 255.255.255.0, use the scroll wheel to highlight OK and click
DRIVE FAULT	The Servo Drive is in a fault state, reset from Spikemark or by removing main power at the breaker for 30 seconds
FWD LIMIT + IP Address	The Forward limit is engaged. Adjust position of roller arm limit switch or manually jog off the limit
REV LIMIT + IP Address	The Reverse limit is engaged. Adjust position of roller arm limit switch or manually jog off the limit
Blank Display	Check main power and local breaker

## Connection/Power

Issue	Checkpoint
Stagehand display is blank	Confirm machine power is connected and local breaker is ON
Able to manually jog the machine from the Stagehand but unable to connect through Spikemark	Confirm IP Address is set correctly on the Stagehand as well as in Spikemark
	Confirm Ethernet cable is connected
	Confirm network switch is connected and powered on

# Rigging

Issue	Checkpoint
Cable is rubbing on keeper	Re-rig so cable is on the correct side of the keeper
Cable not aligned with drum grooves	Re-rig so cable exiting the fairlead pulleys is aligned with the drum groove
	Adjust fairlead pulleys along the ACME rod. See the section titled "Partial Rigging" for instructions.
Drum noise	Confirm fairlead/drum alignment
Excessive cable wear	Confirm fairlead/drum alignment

## TECHNICAL SUPPORT

If you get stuck, we're here to help. The best way to get in touch with a tech expert is via email - even during normal business hours - because most days we are spread around the shop and may not be near the phone. There's someone in the office from 8:30a-5pm EST Monday - Friday and will return an email or phone call quickly. After hours (honestly when most tech support issues arise) we have a crack team monitoring email and voicemail who will respond quickly to help get you moving.

- Online: [www.creativeconnors.com](http://www.creativeconnors.com)
- Email: [support@creativeconnors.com](mailto:support@creativeconnors.com)
- Phone: 401-289-2942



# SPECIFICATIONS

## Maintenance Schedule

Like any machine, the **Pushstick Mini** requires maintenance to stay operating to the fullest capacity.

### Monthly

- Visual inspection of drum, cable, fairlead screw and all pulleys.
  - Excessive cable, drum or pulley wear should be addressed
- Visual inspection of the drive belt (lower)
  - Excessive wear = adjustment or replacement
- Check fairlead ACME rod lubrication
  - If excess dust/dirt is present or if lube is worn away, clean off and reapply

### Semi-Annually

- Wipe off and reapply fairlead lubrication
- Visual inspection of fairlead belt (upper)
- Visual inspection of drive belt (lower) and confirm belt tension
- Visual inspection of electrical and network connections

## Physical Specifications

Description	Value
Continuous Line Pull	90lb
Max Line Pull	270lb
Wire Rope Size	3/16"
Wire Rope Capacity	89' (in addition to (3) safety wraps)
Machine Weight	170lb
Overall Dimensions	36" H x 11.5" W x 22" D

## Electrical Specifications

Description	Value
Input Voltage	120VAC 50/60Hz
Max Input Current	10A
Brake Voltage	24VDC

# Drawings

See attached.