

Creative Conners, Inc

SHOWSTOPPER 3 REMOTE™

REFERENCE MANUAL V1.0

CONTENTS

GETTING STARTED	3
What's included	3
Features	3
INSTALLATION	3
POWERING UP	3
OPERATION	4
TROUBLESHOOTING	5
Common Problems	5
Technical Support	5
SPECIFICATIONS	6
Electrical Specifications	6
Drawings	7

GETTING STARTED

The Showstopper 3 Remote is an additional emergency stop button that can be placed anywhere in the theatre. It extends the safety network of the Showstopper 3 Base or Showstopper 3 Hub. By daisy-chaining Showstopper 3 Remotes, you can add multiple emergency stop buttons to the stage and keep your production safe.

This manual will guide you through:

- Unpacking
- Installation
- Operation
- Troubleshooting

If you need any help along the way, contact us on our website (creativeconners.com), via email (support@creativeconners.com), or by phone (401-289-2942).

WHAT'S INCLUDED

In the box you will find only the Showstopper 3 Remote.

FEATURES

The Showstopper 3 Remote is a 4" x 4" x 2 ½" box with 4 mounting holes. It has 1 Showstopper Accessory input and 1 Accessory output. On the face, there are two indicator lights and a standard locking mushroom cap push button. To release the push button after it has been engaged, simply twist it clockwise.

INSTALLATION

The showstopper 3 Remote has four holes that make it easy to mount to any flat surface. Once in place you will need to connect the accessory cable from the Showstopper 3 Base to the Remote. If the remote is last in line you will need to install a terminator on the Showstopper 3 Remote output, otherwise connect a Showstopper 3 Accessory cable to the output on the Remote and on to additional Showstopper 3 devices. The Showstopper 3 Remote is not a stand-alone device, it must be connected to a Showstopper 3 Base in order to function.

POWERING UP

To power up the Showstopper 3 Remote you will need to power up the entire system. Below you will find an example of a system diagram using two Showstopper 3 Remotes. Once you are sure power is

connected and turned on, you should make sure that no emergency stop button in the system is engaged. If power is connected and no E-stop is engaged, the green indicator light should be illuminated.

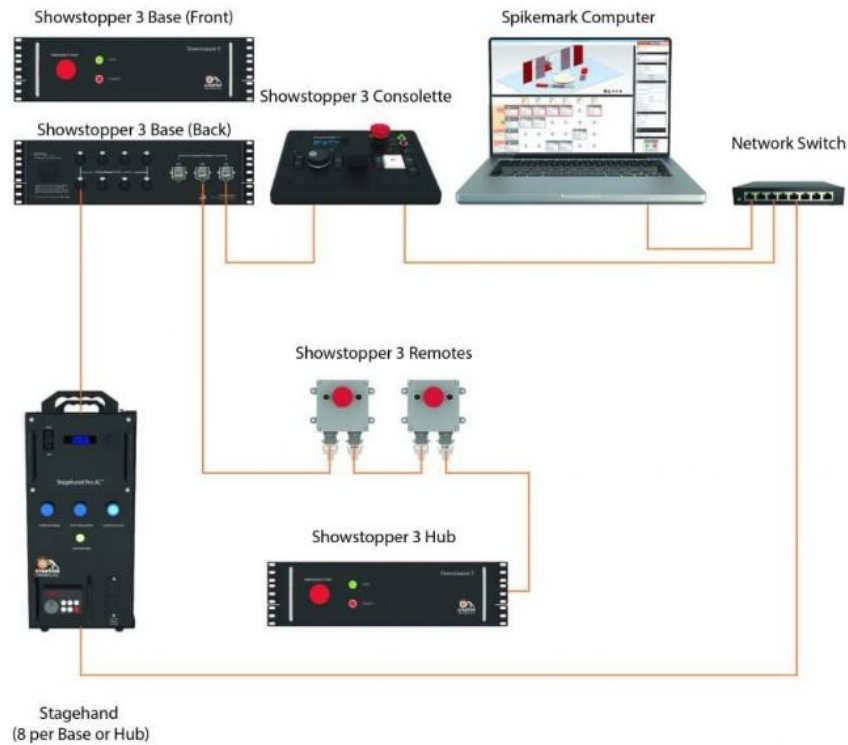

OPERATION

To operate the Showstopper Remote you will need to make sure it is powered. There are two indicator lights on the face of the remote. A green light that indicates that the system is ready to move and no emergency stop is engaged, and a red light that indicates the remote itself has been engaged. If no lights are on then it would indicate that another emergency stop button in the system has been engaged, there is no power to the system, or it is not physically plugged in.

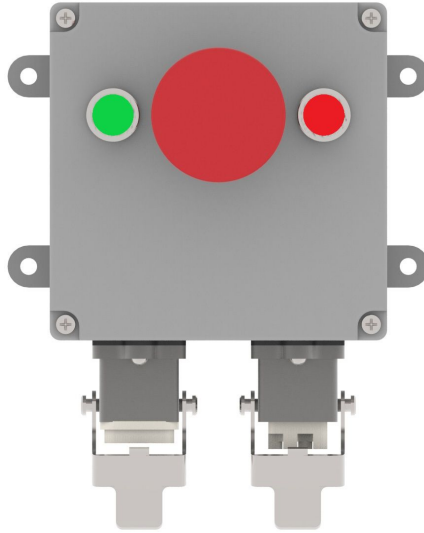

TROUBLESHOOTING

When encountering an issue with the Showstopper Remote the first thing to check would be to make sure that all cables are properly plugged into their respective receivers. Once that has been checked, the next step would be to make sure that power is turned on. If power is turned on and all cables are connected properly then it would be best to make sure no emergency stop button in the system is engaged.

Indicator	Check Power	Local E-Stop Engaged	Another E-Stop Engaged	Ready to Make It Move!
Ready	-	-	-	X
Engaged	-	X	-	-
None	X		X	

COMMON PROBLEMS

The issue that is most often encountered is having an open termination somewhere in the system. The Accessory inputs and outputs must always be terminated. At the Showstopper Base there are three Accessory outputs, there should be a cable or terminator plugged into them for the system to transmit power. Similarly, all remotes in the system should be terminated at the output if it is the last remote in the system or have a cable plugged into both the input and output ports. If you see any Accessory input or output port with nothing plugged into it, the system will not run.

Condition	Remedy
No indicators illuminated	Check mains power
	Confirm no E-stop is activated
	Terminator isn't connected
Red indicator	Local E-stop is activated
Green indicator	Ready to Make It Move!

TECHNICAL SUPPORT

Despite our best efforts and intentions to provide reliable equipment and clear instructions, there may come a time that you need more direct, personal help. We are happy to do that too. Please get in touch in whatever way is most convenient.

PHONE

You can reach us weekdays from 8:30am – 5:00pm EST at 401-289-2942. We keep our eyes (and ears) open even outside of normal business hours because we know rehearsals and performances usually start after 5pm. If we do not answer your call immediately don't despair – leave a message, we are diligently checking voicemails and will call back as soon as possible.

EMAIL

Email is a very convenient tool for technical support, whether you are experiencing a rehearsal-stopping issue or a less critical problem. Emails sent to support@creativeconnors.com are distributed to the entire tech support staff, ensuring the quickest response possible. If you are encountering an issue with a specific cue in a show, please email the show file along with the relevant log file from Spikemark with a description of the issue and ideally a date and time of the incident. We respond within 24 hours, though usually it's only a matter of minutes.

SPECIFICATIONS

ELECTRICAL SPECIFICATIONS

Description	Value
Accessory Input	24VDC
Accessory Output	24VDC

DRAWINGS

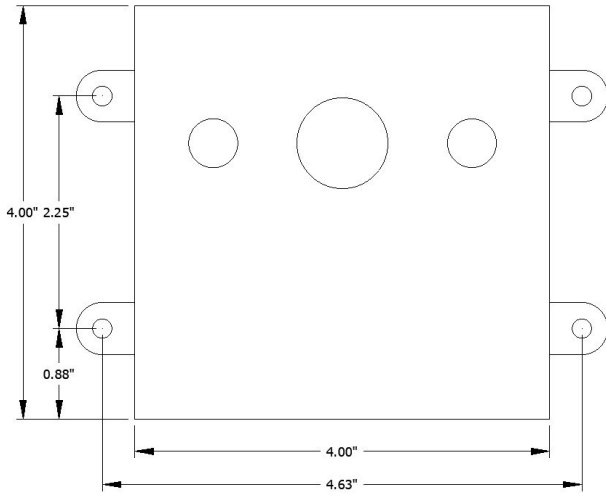

Dimensioned Drawing

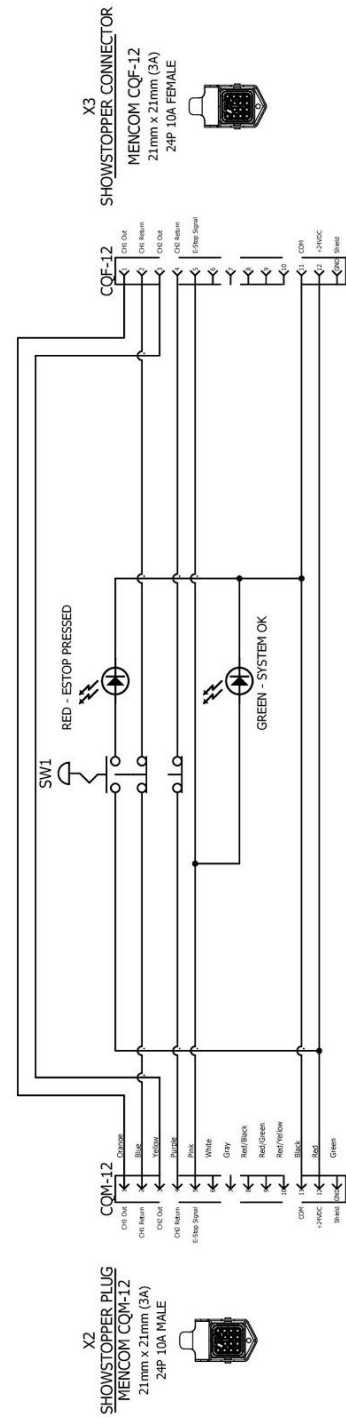

Schematic